

## Escrivaninha c/ Estante

970.00001



### Lista de Materiais Lista de Materiales/ Hardware List

<b>A</b>		Cavilha Ø6x30mm	<b>34</b>	<b>G</b>		Parafuso Ø5,0x50mm cab 10	<b>16</b>
<b>B</b>		Rapid Ø7x30mm	<b>04</b>	<b>H</b>		Sapata 14x5x2,5mm	<b>06</b>
<b>C</b>		Tambor Ø15x12mm	<b>04</b>	<b>I</b>		Chave Zeta	<b>01</b>
<b>D</b>		Tapa furo adesivo Ø18mm	<b>08</b>	<b>J</b>		Haste para Prateleira	<b>02</b>
<b>E</b>		Parafuso Ø3,5x12mm	<b>06</b>	<b>K</b>		Buchas para Parede Ø8mm	<b>02</b>
<b>F</b>		Parafuso Ø3,5x25mm	<b>02</b>				

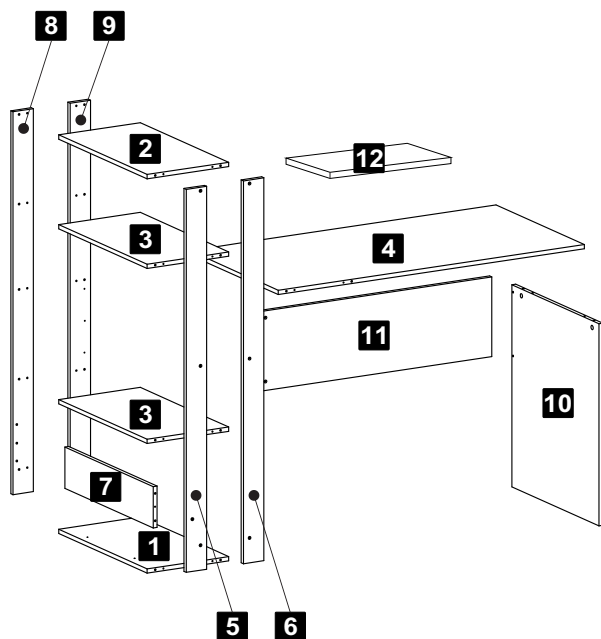

#### Descrição

- 1-Base (600x330x15mm)
- 2-Prateleira (600x330x15mm)
- 3-Prateleira (600x330x15mm)
- 4-Tampo (1200x600x15mm)
- 5-Trav. lateral traseira esq. (1350x80x15mm)
- 6-Trav. lateral frontal esq. (1350x80x15mm)
- 7-Trav. traseira (600x180x15mm)
- 8-Trav. lateral traseira dir. (1350x80x15mm)
- 9-Trav. lateral frontal dir. (1350x80x15mm)
- 10-Lateral (710x540x15mm)
- 11-Travessa tampo (910x300x15mm)
- 12-Prateleira (320x160x15mm)

1

Passo  
Paso  
Step

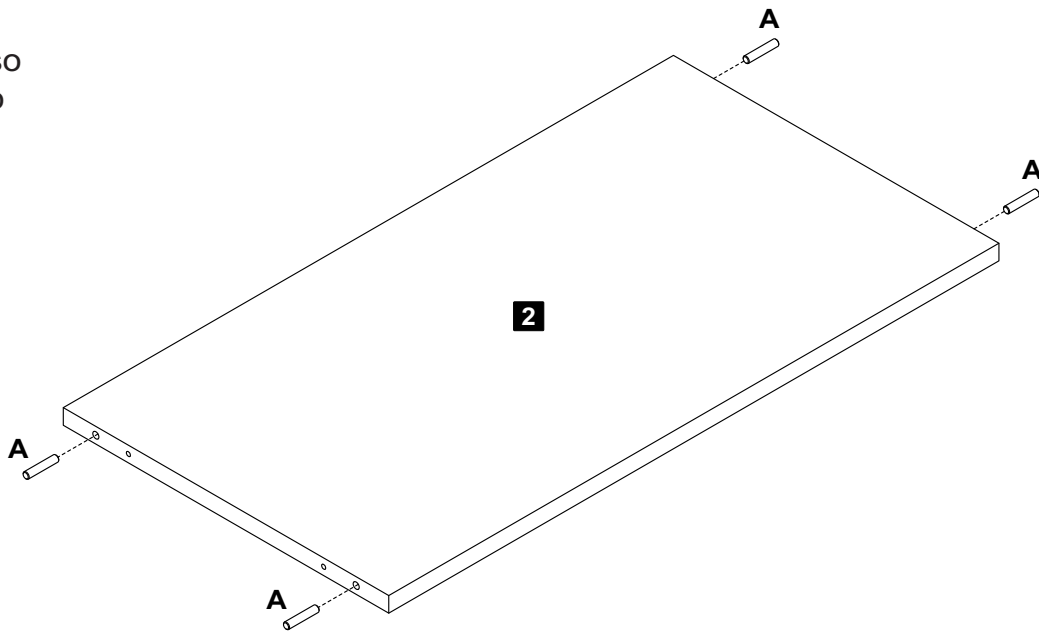

2

Passo  
Paso  
Step

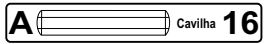
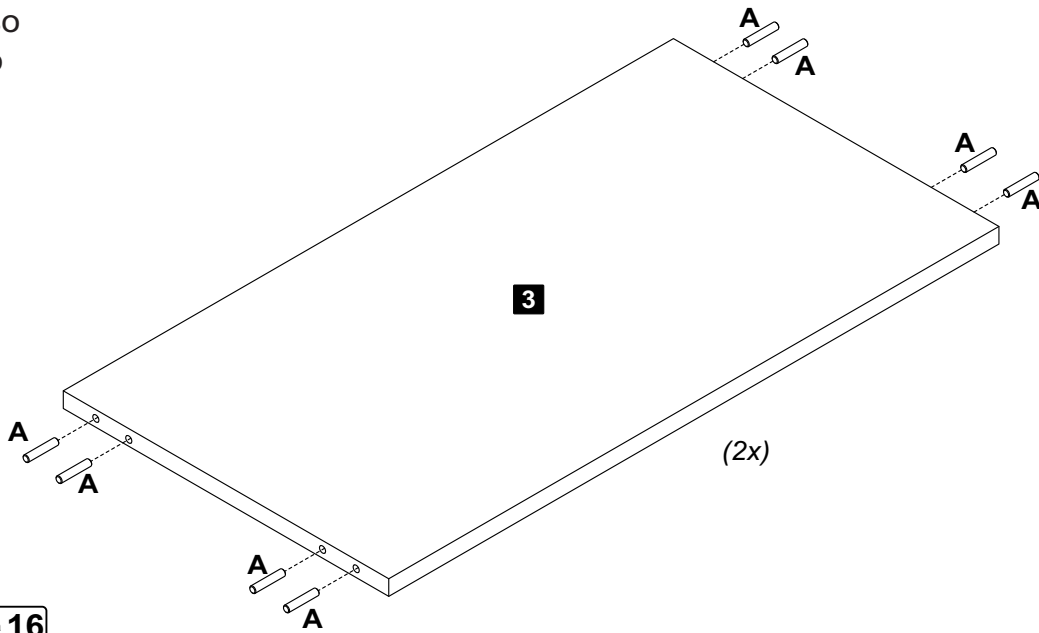

3

Passo  
Paso  
Step

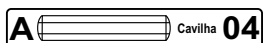
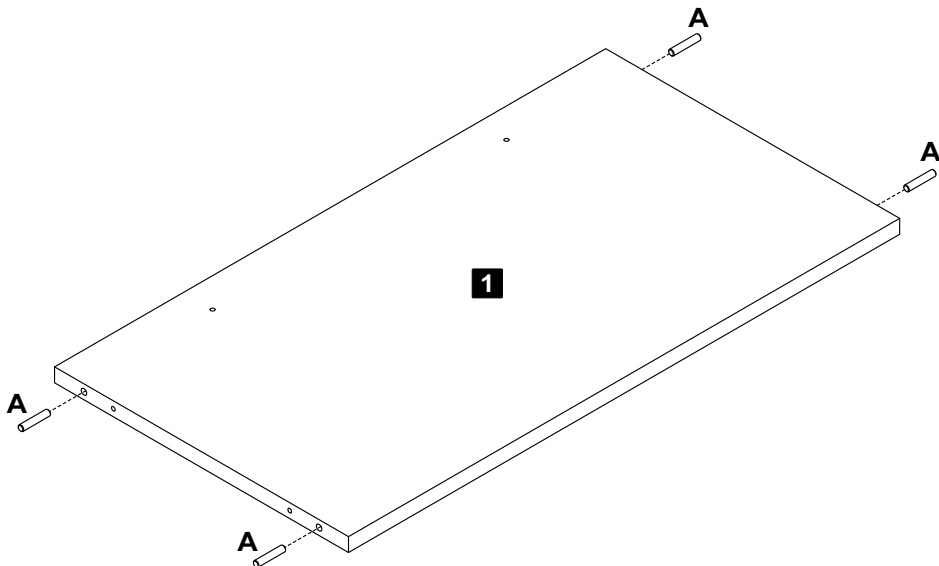

4

Passo  
Paso  
Step

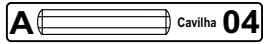
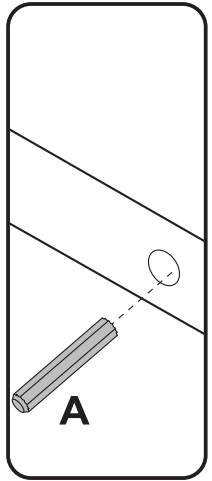
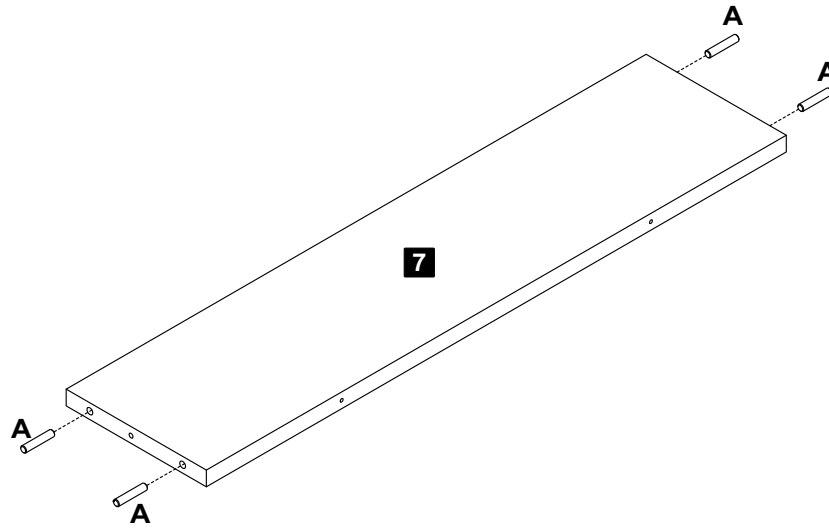

5

Passo  
Paso  
Step

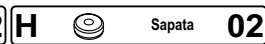
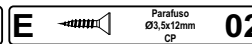
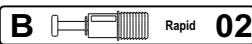
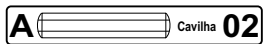
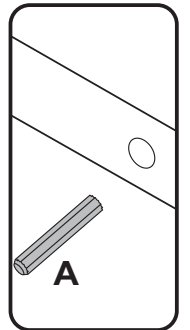
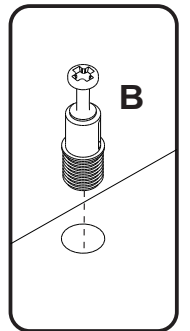
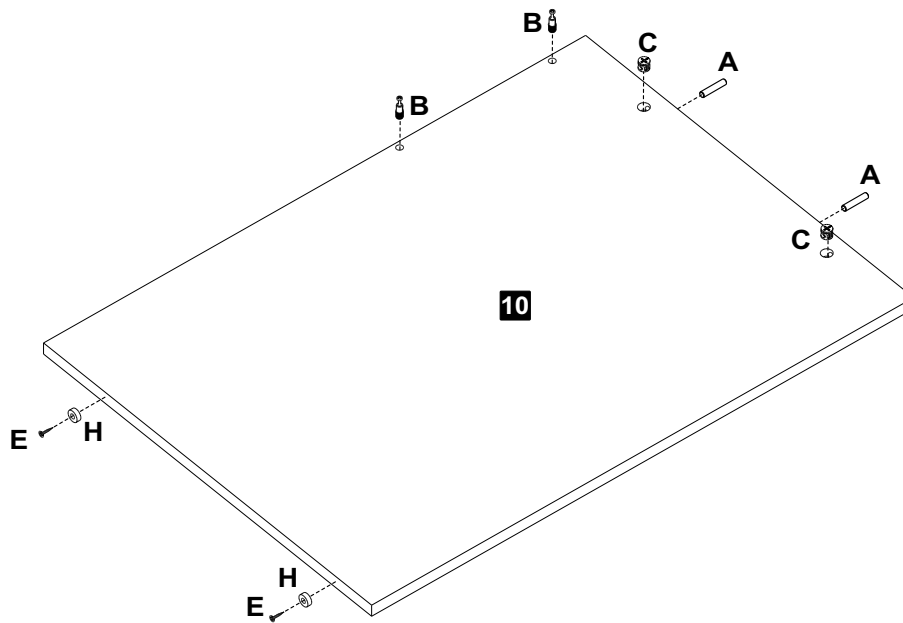

6

Passo  
Paso  
Step

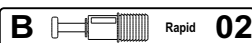
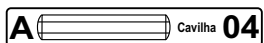
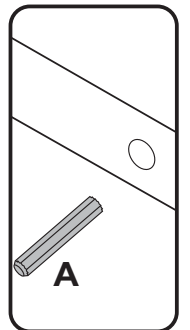
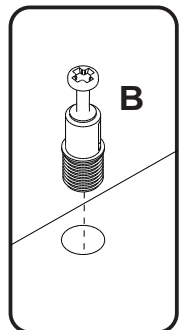
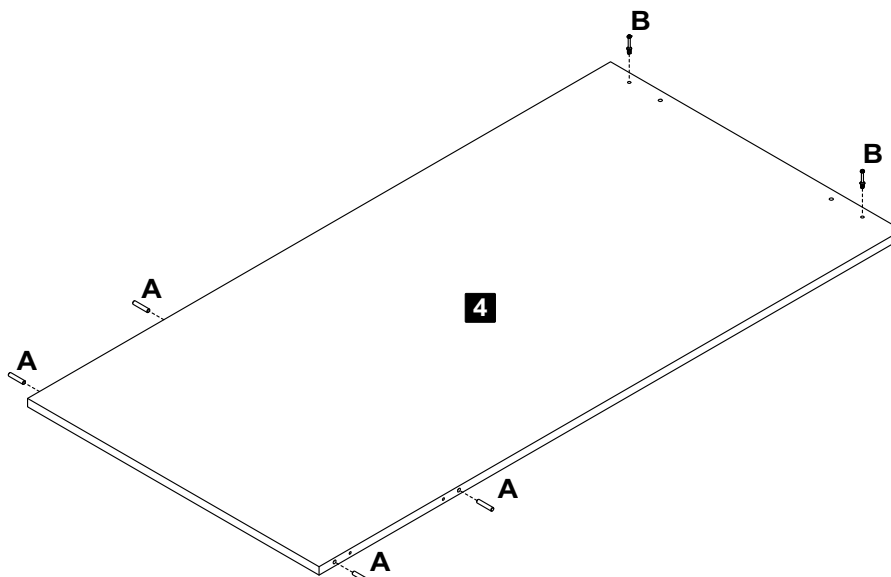

**7** Passo  
Paso  
Step

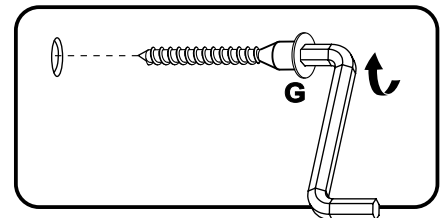
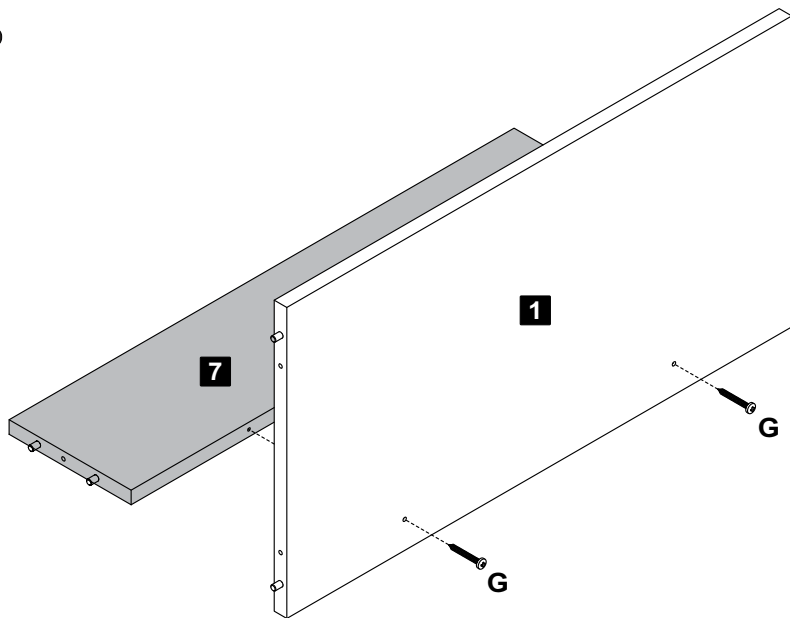

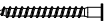
**G**  Parafuso  
Ø5,0x50mm  
CP **02**

**8** Passo  
Paso  
Step

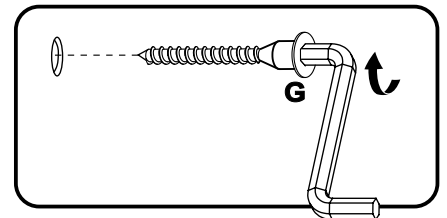
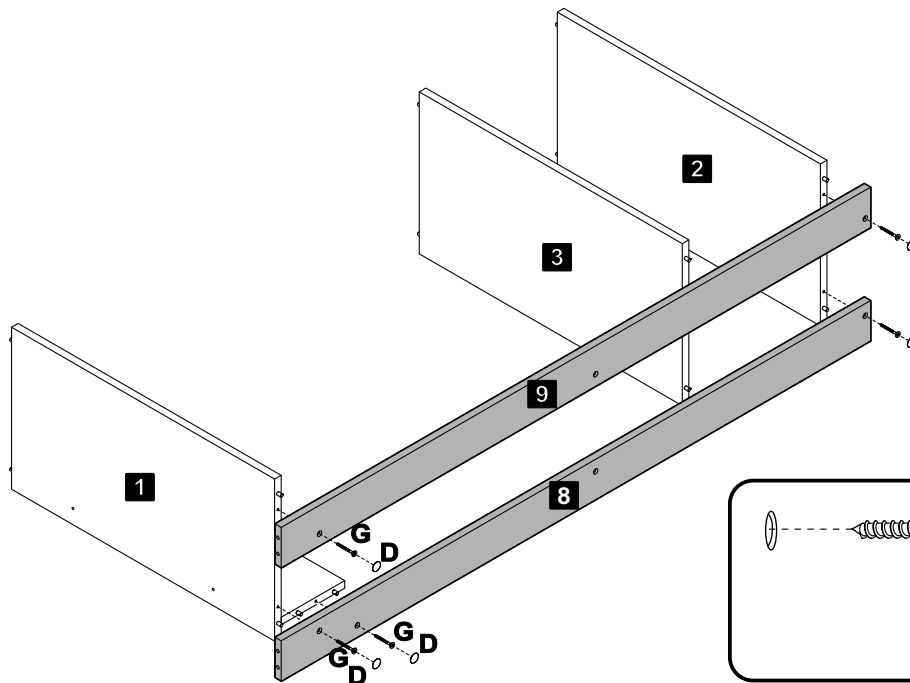

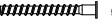
**G**  Parafuso  
Ø5,0x50mm  
CP **05**

**9** Passo  
Paso  
Step

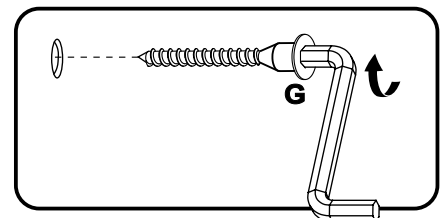
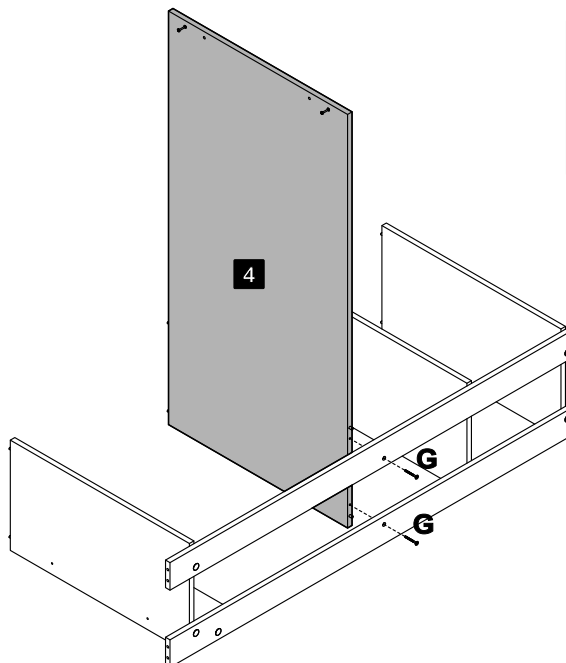

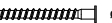
**G**  Parafuso  
Ø5,0x50mm  
CP **02**

10

Passo  
Paso  
Step

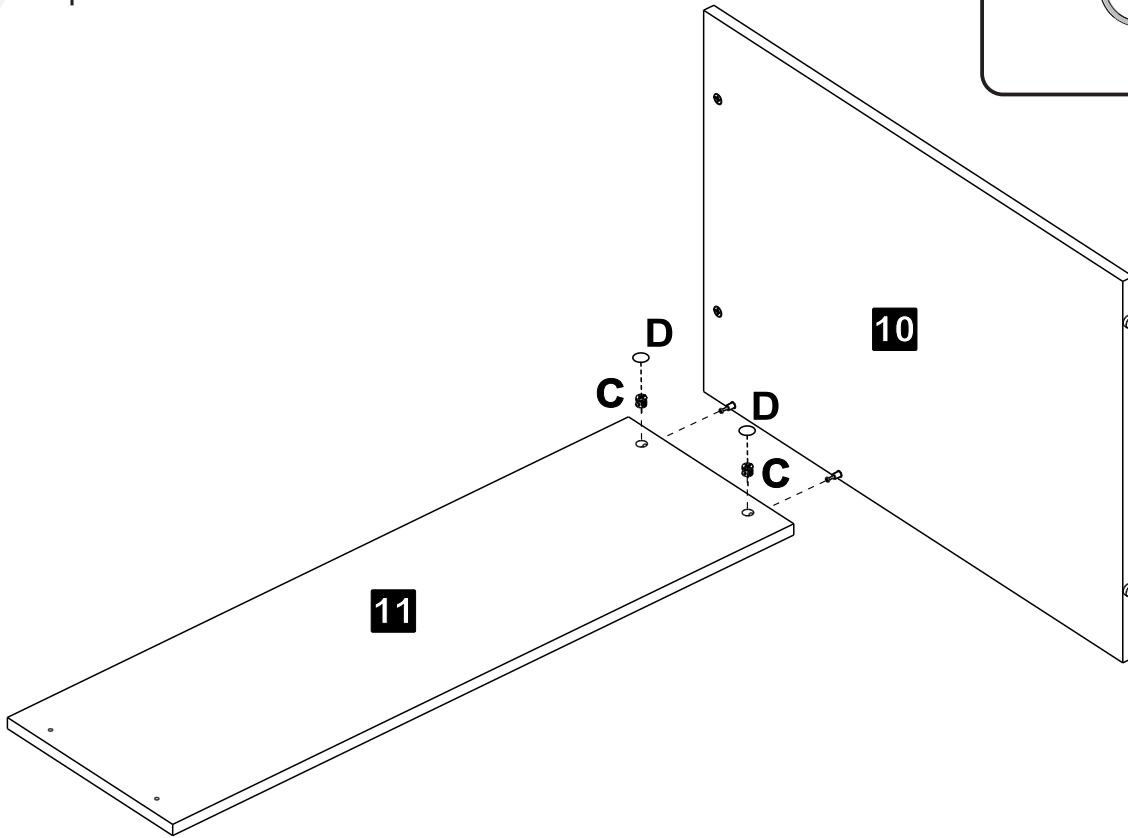

**C**  Tambor 02 **D**  Tapa Furo Adesivo 02

11

Passo  
Paso  
Step

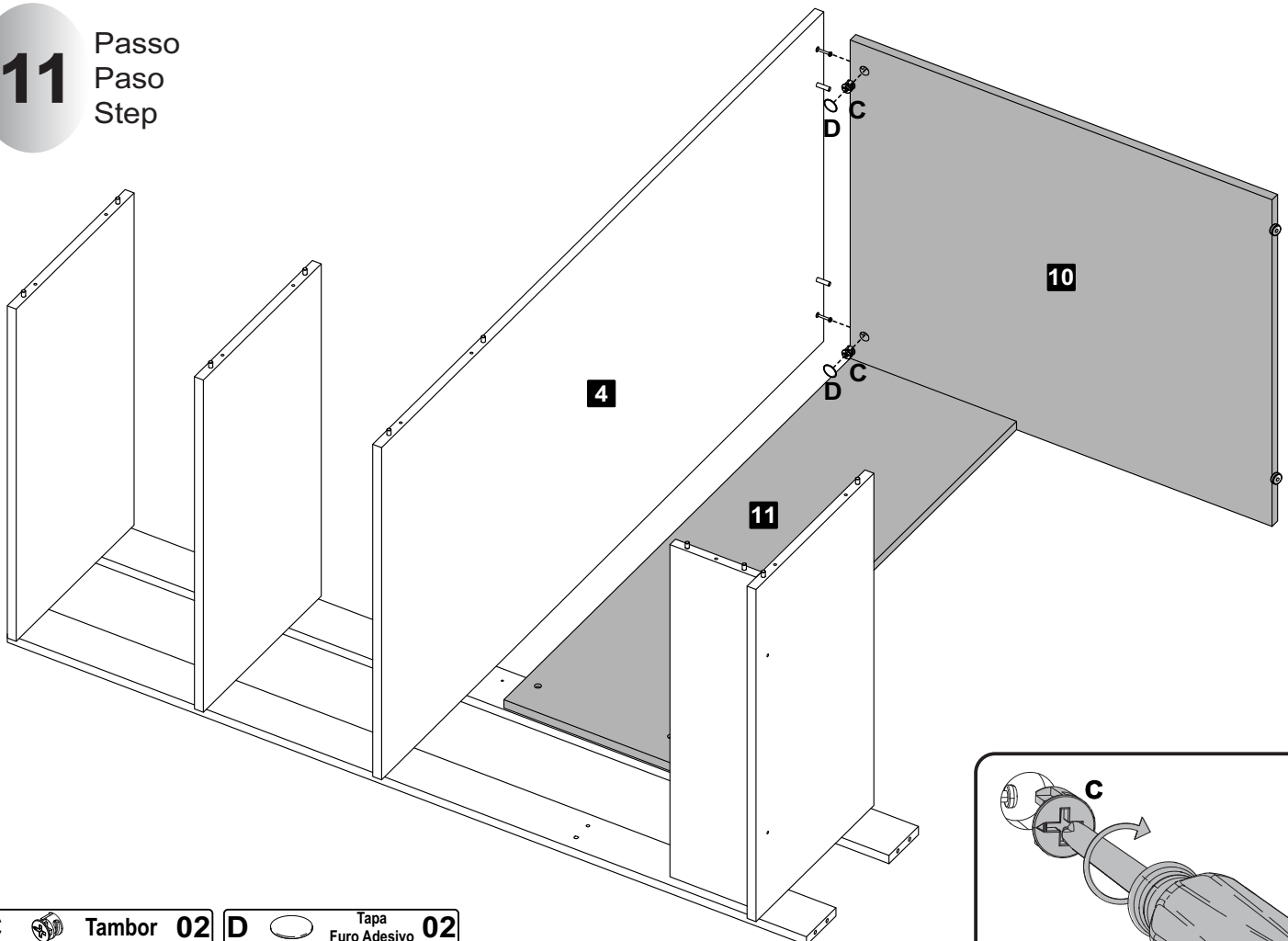

**C**  Tambor 02 **D**  Tapa Furo Adesivo 02

12

Passo  
Paso  
Step

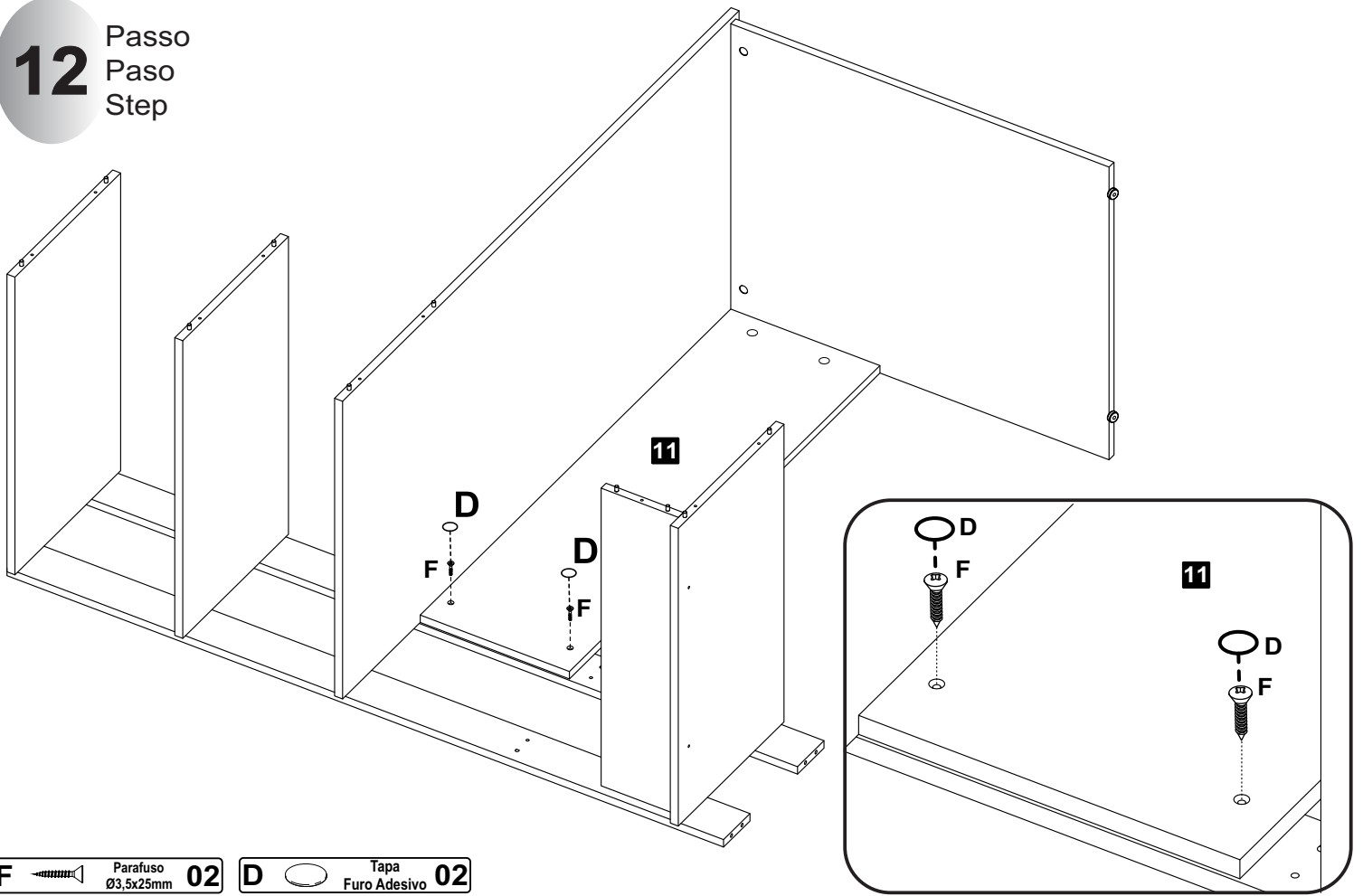

**F** Parafuso Ø3,5x25mm 02

**D** Tapa Furo Adesivo 02

13

Passo  
Paso  
Step

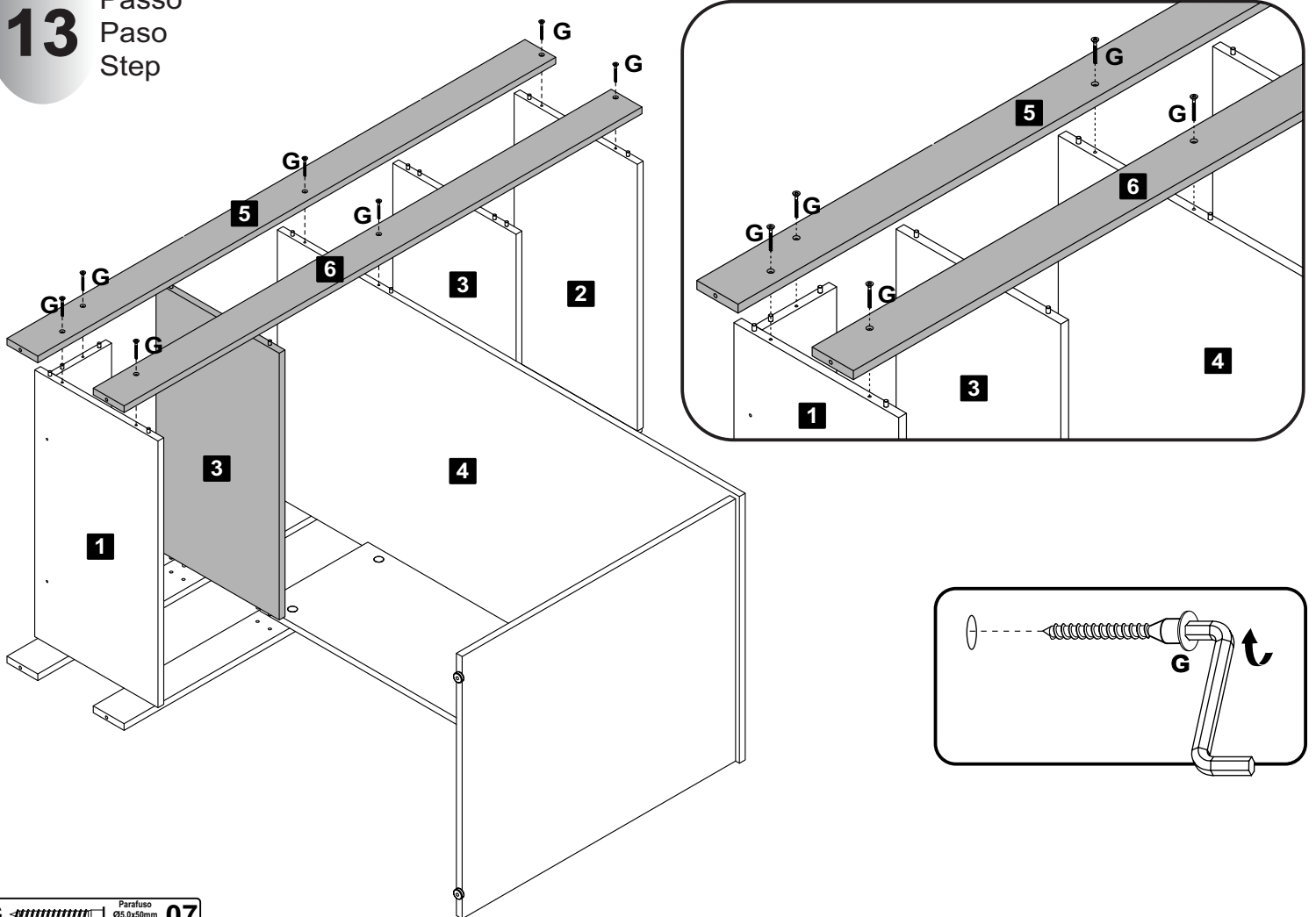



**G** Parafuso Ø5,0x50mm CP 07

14

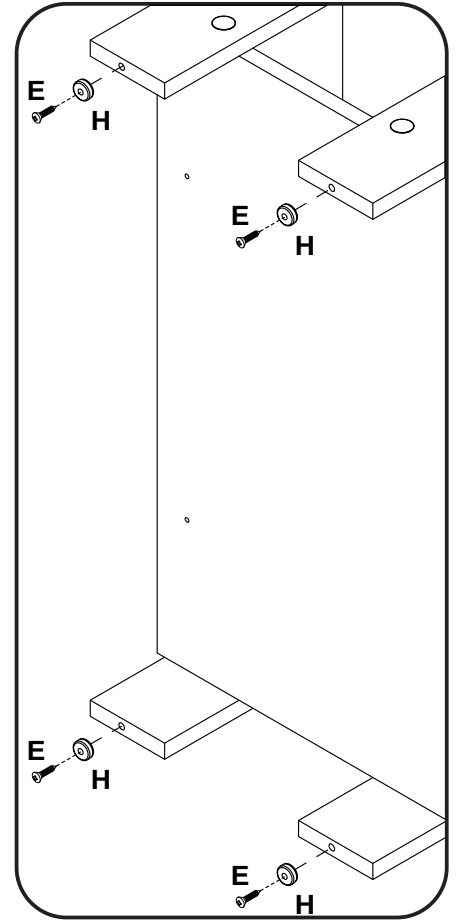
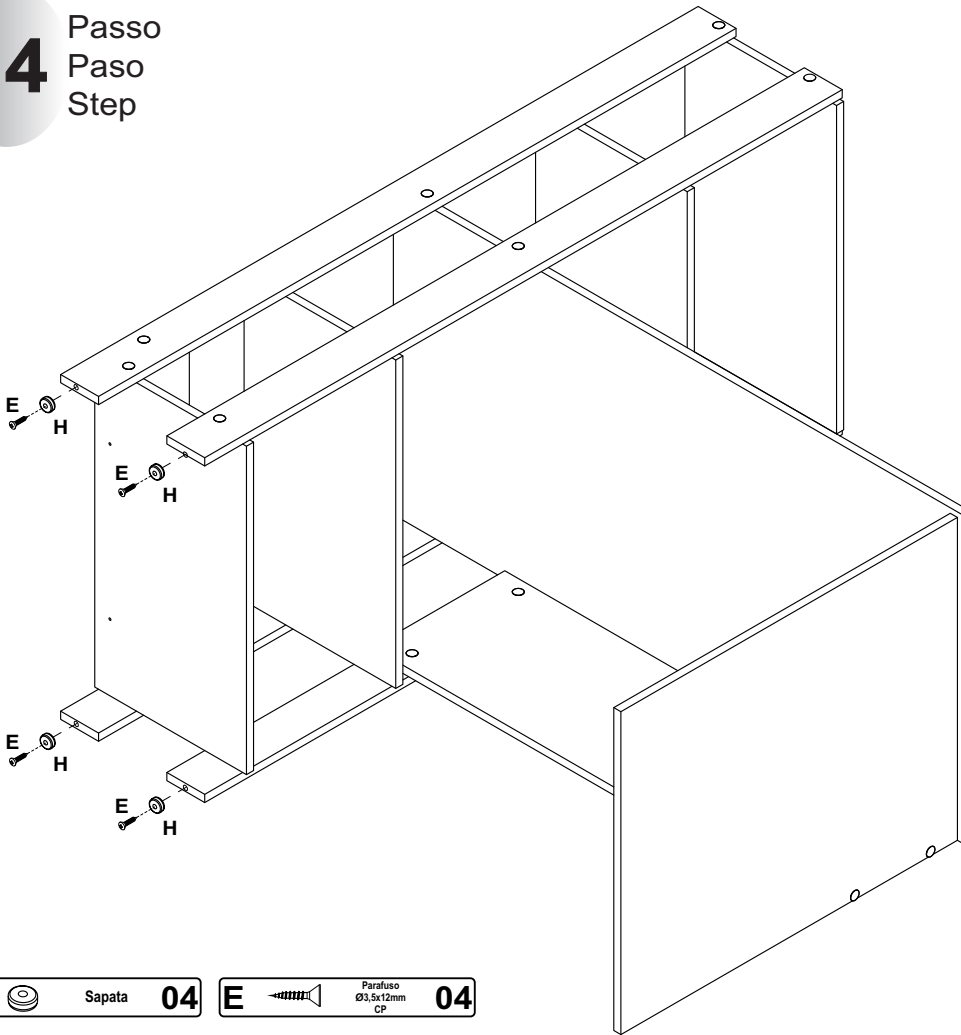
Passo  
Paso  
Step



H  Sapata 04

E  Parafuso Ø3,5x12mm CP 04

15

Passo  
Paso  
Step

Furo  
Ø8mm

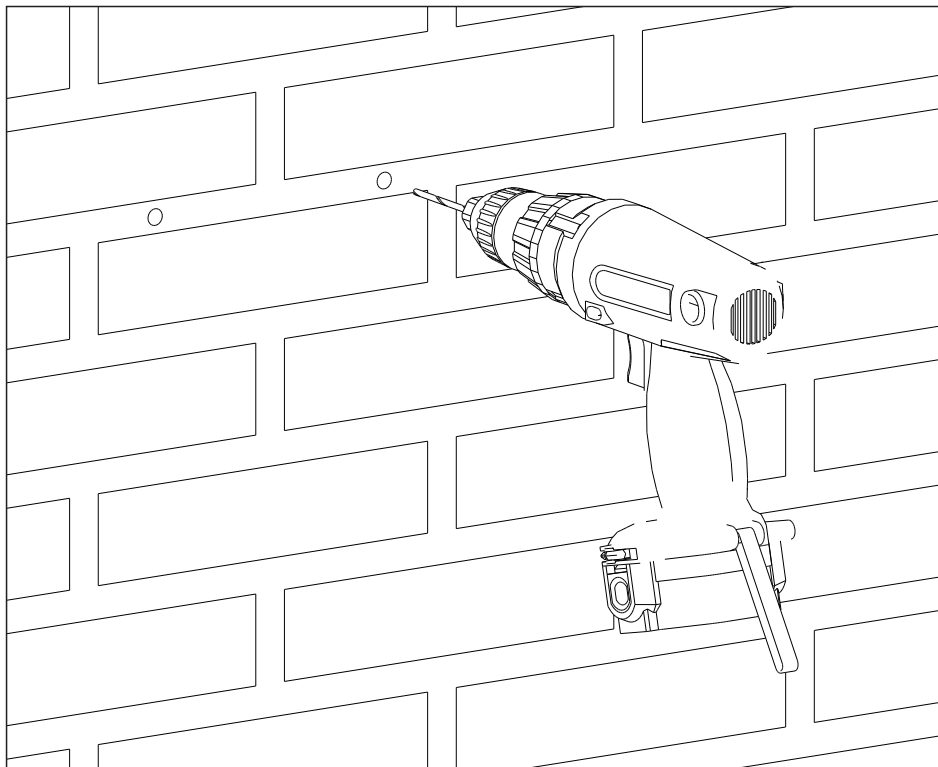

16

Passo  
Paso  
Step

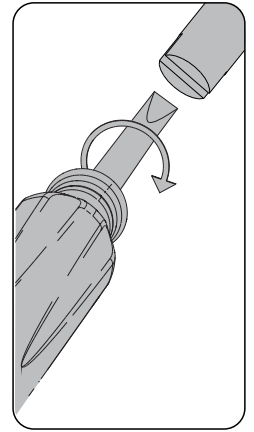
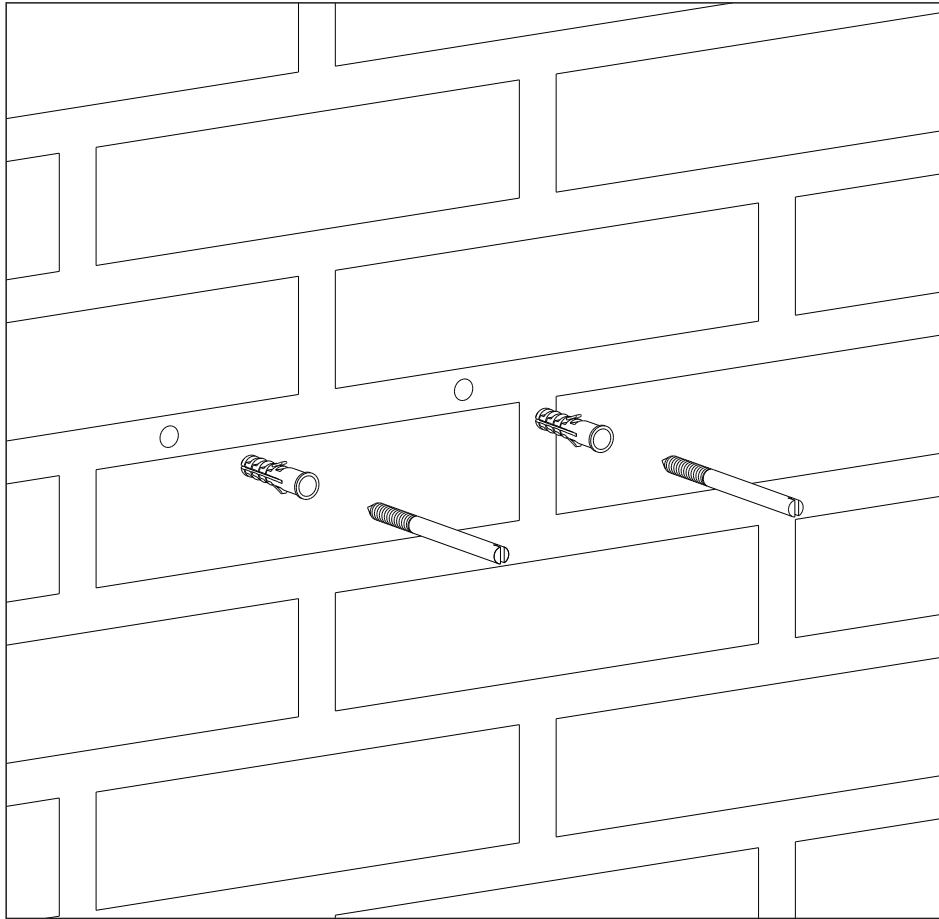

**J**  Haste para Prateleira  
Barras de Açoqali / Shelf Rod 02

**K**  Bucha para Parede  
Bujes de Parede / Wall Plug 02

17

Passo  
Paso  
Step

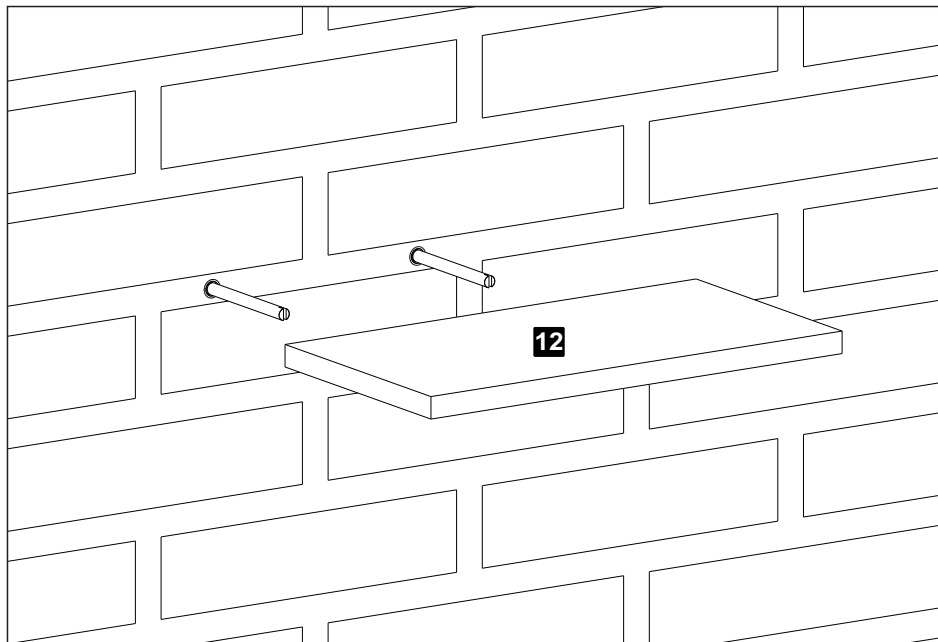



18

Passo  
Paso  
Step

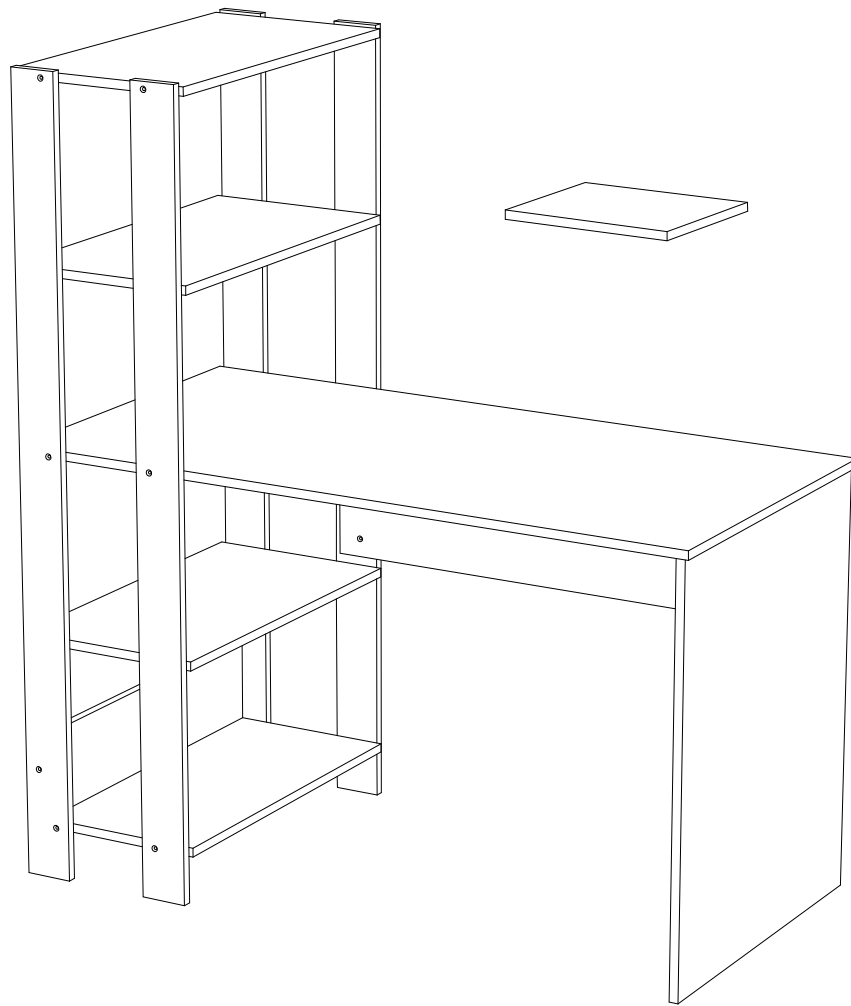



MARCAÇÃO PARA O SUPORTE DA PRATELEIRA

